

RELEASE

DATE:

COMPANY:

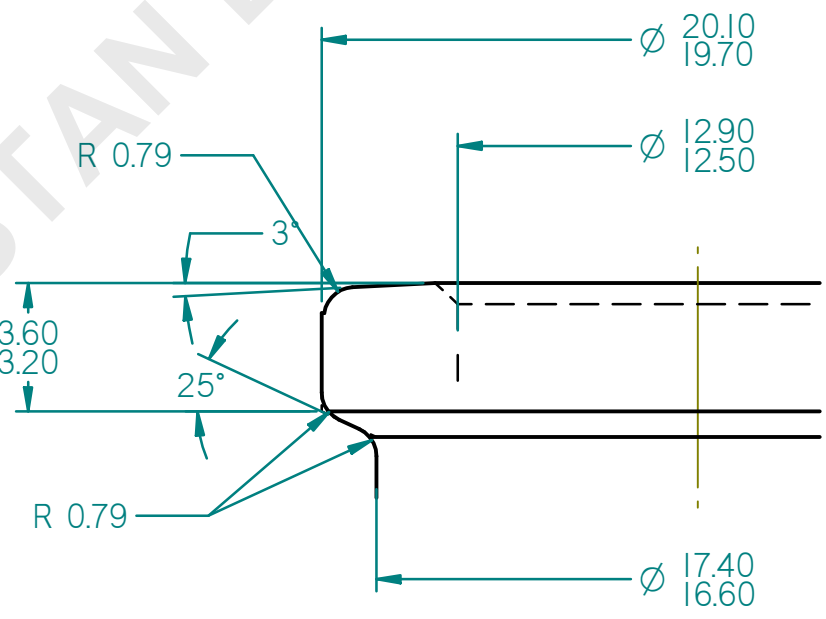
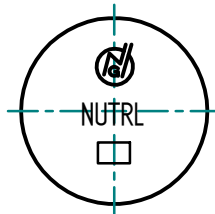
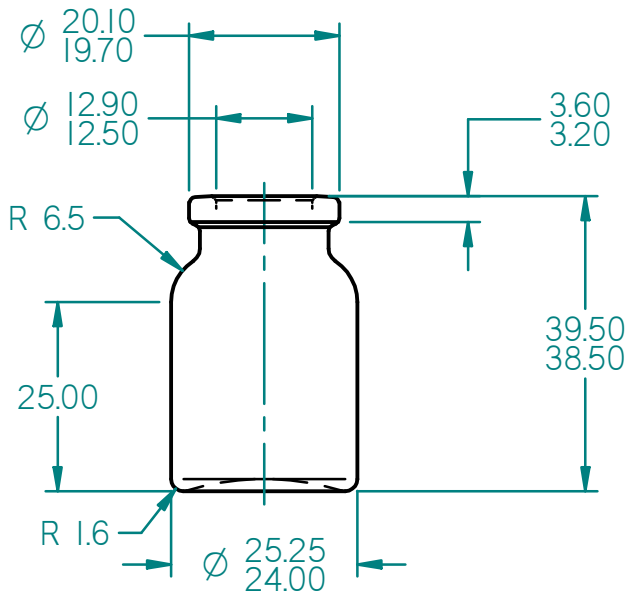

FINISH : 20 mm STD.

Protective note ISO 16016 observed

GENERAL TOLERANCES DIN 6129-1 (DIMENSIONS WITHOUT TOLERANCES ARE FOR REFERENCE ONLY)				FINISH: 20 mm STD.		O'FLOW CAPACITY: 9.50 - 10.50 ml		ARTICLE NO.: 5151030100		
				FINISH DWG: N.A.		WEIGHT: 14 g Approx.				
				FINISH MOLD NO: 910		TYPE OF GLASS: I COLOUR: FLINT				
				DATE	NAME	TITLE: 5 ml NATIONAL				
				DRAWN	20/11/2013					Paresh
				CHECKED	20/11/2013					H.B.P.
				SCALE	1 : 1, 5 : 1					
				GERRESHEIMER NEUTRAL GLASS & ALLIED INDS. PVT. LTD. MUMBAI / KOSAMBA		MOLD NO.:	DRAWING NO.:	REVISION	SHEET	FORMAT
						032	B 1030	0	1 OF 1	A4
REV.	CHANGE	DATE	NAME			FILE: 5 ml National.dft				